

## Control Accessories

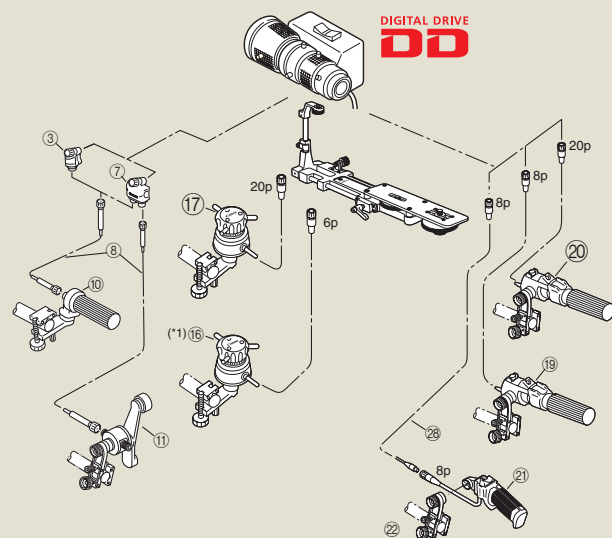

### Applicable Kit Detail

	Kit Name	Zoom		Focus	
		System	Component	System	Component
<b>for HJ40x10B IASD-V, HJ40x14B IASD-V</b>					
Zoom Servo Only	--	ZR-1	(19)*	--	--
	--	ZR-1D	(21) (22) (23)	--	--
	--	ZR-2(A)	(21) (22) (23)	--	--
Semi-Servo	--	ZR-1	(19)*	FR-2	(3) (8) (10)
	--	ZR-1D	(21) (22) (23)	FR-2	(3) (8) (10)
	--	ZR-2(A)	(21) (22) (23)	FR-2	(3) (8) (10)
Full Servo	SS-41-IAS	ZR-1	(19)*	FPS-4	(16) (22)
	SS-41-IASD	ZR-1D	(21) (22) (23)	FPS-4D	(16) (22)
	SS-42-IAS	ZR-2(A)	(21) (22) (23)	FPS-4	(16) (22)
Full Manual	--	FZC-1	(7) (8) (11)	FR-2(w/o 3)	(8) (10)

\* If a ZSD-300A Demand or ZSG-200A Grip will be used with a DD (Digital Drive) B3 mount lens, please contact a Canon office for special operating instructions.

□ Recommended Kit Configuration for the Digital lenses.

● The controllers support the new DD functions.

(\*1) (2) CC-2006 conversion cable is necessary to connect between IASD Digital Lens and FPD-400.

## DIMENSIONS

HJ40x10B IASD-V (Unit:mm)

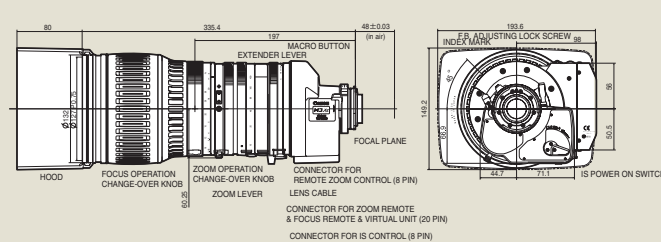

HJ40x14B IASD-V (Unit:mm)

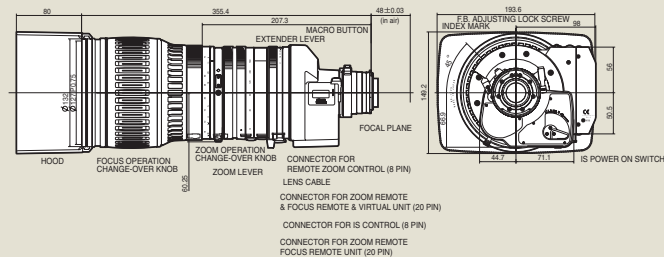

**North & South America**  
**Canon U.S.A., Inc.**  
 Broadcast & Communications Div. (Headquarters)  
 65 Challenger Road, Ridgefield Park, NJ07660  
 Tel:(201)807-3300/(800)321-4388  
 Fax:(201)807-3333  
 Email:bctv@cusa.canon.com  
<http://www.canonbroadcast.com/>

**Chicago**  
 100 Park Blvd. Itasca, IL 60143  
 Tel:(630)250-6236 Fax:(630)250-0399

**Atlanta**  
 5625 Oakbrook Pkwy. Norcross, GA 30093  
 Tel:(770)849-7890 Fax:(770)849-7888

**Los Angeles**  
 15955 Alton Parkway Irvine, CA 92618  
 Tel:(949)753-4330 Fax:(949)753-4337

**Dallas**  
 3200 Regent Blvd. Irving, TX 75063  
 Tel:(972)409-8871 Fax:(972)409-8669

**Latin America**  
 Tel:(954)349-6975 Fax:(201)807-3333

**Canada**  
**Canon Canada, Inc.**  
 Broadcast and Communications Div.  
 6390 Dixie Road  
 Mississauga, Ontario, L5T 1P7, Canada  
 Tel:(905)795-2012 Fax:(905)795-2140

**Europe/Africa/Middle East**  
**Canon Europa N.V.**  
 Broadcast and Communications Div.  
 Boyenkerkerweg 59-61  
 1185 XB Amstelveen  
 Tel:+31(0)20-5458905 Fax:+31(0)20-5458203  
 Email:tvprod@canon-europe.com  
<http://www.canon-europe.com/tv-products>

**Australia**  
**Canon Australia Pty. Ltd.**  
 Optical Products Division  
 1 Thomas Holt Drive, North Ryde, NSW 2113,  
 Australia  
 Tel:+61(0)2-9805-2000 Fax:+61(0)2-9805-2444

**China**  
**Canon (China) Co., Ltd.**  
 Optical Products Division  
 15F South Tower, Beijing Kerry Center, 1 Guang  
 Hua Road, Chao Yang District, 100020, Beijing,  
 China  
 Tel:(010)8529-8488 ex 133 Fax:(010)8529-6606  
<http://www.canon.com.cn>

Distributed by



Specifications subject to change without notice.

**Canon**

**HJ40x10B**  
**HJ40x14B**



**Canon**



# HJ40x10B IASD-V (10-400mm 1:2.0)

# HJ40x14B IASD-V (14-560mm 1:2.8)



Canon proudly offers our HD portable lens series; the HJ40x10B IASD-V & HJ40x14B IASD-V. The compact HJ40x11B/HJ40x14B achieves superior optical performance and high specifications at the same time, featuring a superior built-in Image Stabilizer which adds a perfect stability to your video production. The HJ40x10B/14B series is designed to meet the high demands of all field production applications. The lens will surely lead you to a higher standard of production.

## Canon's Technology

### Optical Shift Image Stabilizer (Shift-IS)

When the lens moves, the light rays from the subject are bent relative to the optical axis, resulting in an unsteady image because the light rays are deflected. By shifting the IS lens group on a plane perpendicular to the optical axis to counter the degree of image shake, the light rays reaching the image plane can be steadied. Since image shake occurs in both horizontal and vertical directions, two shake detecting sensors for yaw and pitch, detect the angle and speed of movement and send this information to a high-speed 32-bit microcomputer, which converts the information into drive signals for the IS lens group. Then the actuator moves the IS lens group horizontally and vertically thus counteracting the image shake and maintaining the stable picture. The Shift-IS component is located within the lens group and is most effective for lower frequency movements caused by platform vibration or wind effect without increasing the overall size and weight of the master lens.

IMAGE STABILIZER

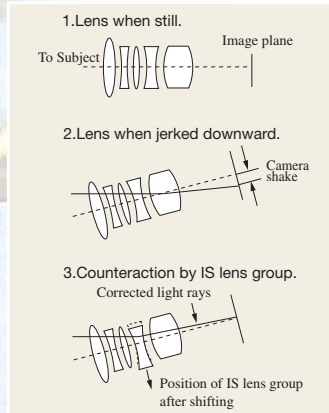

### Enhanced Optical Technology

#### Special Optical Elements

Canon has always made an effort to research special optical elements since our beginnings in this industry with the goal of minimizing chromatic aberration. These efforts have included an artificial element, "Fluorite", with extraordinary dispersion characteristics and the newly developed "Hi-UD" (high index ultra low dispersion) glass. Canon has succeeded in the practical use of special elements along with advanced design techniques like "separate achromatism". Canon TV zoom lenses carry a "Green Ring" on the focus barrel, a symbol of our high quality. Canon has developed a breakthrough in optical design technology known as the "Power Optical System" whose heart is the "X-Element". By using the "X-Element" to its maximum power in the specially designed optical layout, higher specifications and quality can be achieved in smaller and lighter lenses. The lenses designed using the "Power Optical System" are known as the "XS-series".

#### Aberration Correction for HDTV Lenses

The pixel size is about half in the HDTV system, and therefore the spread of a point image caused by a spherical aberration, coma, etc. should be diminished to about half. Even if the image is slightly out of focus, MTF is greatly influenced. The graph 1 shows how MTF varies when the focus changes. Canon HDxs series lenses employ the HD version of the Power Optical System, which incorporates the X-Element. HDxs greatly contributes to correcting and minimizing these aberrations at the same time, maintaining high MTF throughout the edge of the picture (graph 2).

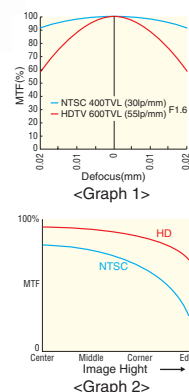

### Digital Drive Unit

The HJ40x is equipped with a Digital Drive Unit which offers diverse unique digital functions. The followings are the basic three preset functions that have become possible with the digital technology. The concept of the Digital Drive is based on "Ease of Operation" which enables you to use the diverse digital functions, precisely, easily and fully.

## Main Features

### Shuttle Shot

By memorizing any two focal lengths, the Digital Drive can automatically "shuttle" between the two points, moving in either direction.



### Framing Preset

An angle of view can be preset in either of two memories and the lens will zoom to that position by pushing a simple button. During a performance, framing preset will reproduce the zoom position decided upon at the rehearsal. It's easy to repeat the same zoom as often as you like at the highest speed or in a preset zoom speed.



### Speed Preset

A specific zoom speed can be preset in memory and it is possible to repeat the zoom speed as often as you like by pushing a simple button.



### [Digital Drive Unit]



Return Switch  
Framing Preset Switch  
Speed Mode Change Over Lever

Memory Switch  
Zoom Operation Switch



Long Focal Length of 10-400mm/14-560mm (20-800mm/28-1120mm With 2x Ext.) With Reduced Distortion.

Built-in 2x Extender

High and Flat MTF **HD XS**  
Realization of high contrast in all areas of the picture (Center-Corner).

### [High Zoom Ratio]

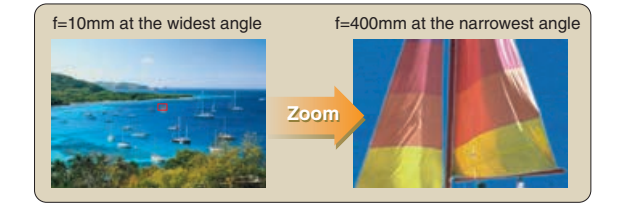

(HJ40x10B IASD-V)

### [Enhanced Image Stabilizing System (Shift-IS)]



### Ecological Design

It is Canon's policy not to pollute the earth and the HJ40x series have avoided using any materials or substances that could pollute the environment.

## SPECIFICATIONS

HJ40x10B IASD-V	16:9		SWITCHABLE 4:3	
Built-in extender	1.0X	2.0X	1.2X	2.4X
Zoom Arrio	40X			
Range of Focal Length	10~400mm	20~800mm	10~400mm	20~800mm
Maximum Relative Aperture	1:2.0 at 10~220mm 1:3.65 at 400mm	1:4.0 at 20~440mm 1:7.3 at 800mm	1:2.0 at 10~220mm 1:3.65 at 400mm	1:4.0 at 20~440mm 1:7.3 at 800mm
Angular Field of View	51.3°× 30.2° at 10mm 1.4°× 0.8° at 400mm	27.0°× 15.4° at 20mm 0.7°× 0.4° at 800mm	39.6°× 30.2° at 10mm 1.0°× 0.8° at 400mm	20.4°× 15.4° at 20mm 0.5°× 0.4° at 800mm
Minimum object Distance (M.O.D)	2.8m (10mm with Macro)			
Object Dimensions at M.O.D	248.4×139.7cm at 10mm 6.2×3.5cm at 400mm	124.2×69.9cm at 20mm 3.1×1.8cm at 800mm	186.3×139.7cm at 10mm 4.7×3.5cm at 400mm	93.2×69.9cm at 20mm 2.4×1.8cm at 800mm
Approx. Size	W×H×L = 174.1×133.0×335.4 mm			
Approx. Mass (IRSE/IASE)	5.40Kg (11.90lbs)			

HJ40x14B IASD-V	16:9		SWITCHABLE 4:3	
Built-in extender	1.0X	2.0X	1.2X	2.4X
Zoom Arrio	40X			
Range of Focal Length	14~560mm	28~1120mm	14~560mm	28~1120mm
Maximum Relative Aperture	1:2.8 at 14~307mm 1:5.1 at 560mm	1:5.6 at 28~614mm 1:10.2 at 1120mm	1:2.8 at 14~307mm 1:5.1 at 560mm	1:5.6 at 28~614mm 1:10.2 at 1120mm
Angular Field of View	37.8°× 21.8° at 14mm 1.0°× 0.6° at 560mm	19.4°× 11.0° at 28mm 0.5°× 0.3° at 1120mm	28.8°× 21.8° at 14mm 0.7°× 0.6° at 560mm	14.7°× 11.0° at 28mm 0.4°× 0.3° at 1120mm
Minimum object Distance (M.O.D)	2.8m (10mm with Macro)			
Object Dimensions at M.O.D	177.1×99.5cm at 14mm 4.5×2.5cm at 560mm	88.6×49.8cm at 28mm 2.3×1.3cm at 1120mm	132.8×99.5cm at 14mm 3.4×2.5cm at 560mm	66.4×49.8cm at 28mm 1.7×1.3cm at 1120mm
Approx. Size	W×H×L = 174.1×133.0×355.5 mm			
Approx. Mass (IRSE/IASE)	5.45Kg (12.02lbs)			